

Cooper Bussmann

[Homepage](#)
[About Cooper Bussmann](#)
[Contact Us](#)
[Privacy](#)
[Legal](#)
[Cooper Bussmann® Brand](#)
[Site Map](#)

S506-630-R

TIME DELAY, 5 X 20 mm, GLASS T

Product Information

| | |
|-----------------|-----------------|
| Product Type: | Fuse |
| Product Family: | Electronic |
| Brand: | Cooper Bussmann |

Recommended Products

| | |
|-------------------------------|-------------------------------|
| Rec. Fuse Block: | HTC-15M |
| Rec. Inline Fuse Holder: | HHT |
| Rec. Panel-mount Fuse Holder: | HTB Series |
| Rec. Fuse Clips: | 1A3399 Series |

Physical Properties

| | |
|-------------|-----------------------------------|
| Dimensions: | 0.79in.(L) × 0.19in.(W) × 0in.(H) |
|-------------|-----------------------------------|

Electrical Properties

| | |
|--------------------------|--|
| Maximum AC Voltage: | 250 |
| Amperage Rating: | 0.63 |
| AC Interrupting Ratings: | <ul style="list-style-type: none"> • 35 at 250V |
| Time Delay: | Yes |

5 x 20mm Fuses

S506 Series, Time-Delay, Glass Tube

Description

- Time-delay, low breaking capacity
- Optional axial leads available
- 5 x 20mm physical size
- Glass tube, nickel-plated brass endcap construction
- Designed to IEC 60127-2 (32mA-10A)

| S506 Electrical Characteristics | | | | | | | | |
|---------------------------------|-----------|--------|------------|--------|---------|-------|----------|--|
| I_n | $2.1 I_n$ | | $2.75 I_n$ | | $4 I_n$ | | $10 I_n$ | |
| | max | min | max | min | max | min | max | |
| 32mA-100mA | 2 min | 200 ms | 10 sec | 40 ms | 3 sec | 10 ms | 300 ms | |
| 125mA-6.3A | 2 min | 600 ms | 10 sec | 150 ms | 3 sec | 20 ms | 300 ms | |
| 8A-15A | 2 min | 600 ms | 10 sec | 150 ms | 3 sec | 20 ms | 300 ms | |

Agency Information

- UL Recognized Card: (32mA-15A) Guide JDYX2, File E19180
- CSA Component Acceptance: File 53787, 50mA-10A
- cURus Recognition: Guide JDYX8, File E19180
- SEMKO Approval, 32mA-10A
- VDE Approval, 32mA-10A
- BSI Approval, 32mA-10A
- IMQ Approval, 32mA-10A
- PSE Approval, 1A-15A
- CCC Approval, 32mA-6.3A

Ordering

- Specify packaging, product, and option code



Dimensions - mm

Drawing Not to Scale

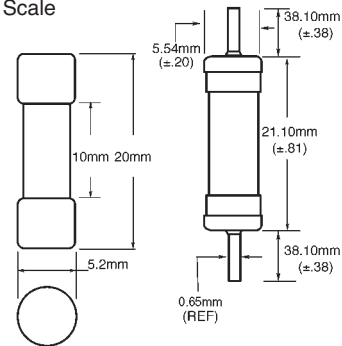

- Ratings above 4A have a 0.8mm diameter lead
- With TR2 packaging code, lead wire length is 19.05mm

Specifications

| Product Code | Voltage Rating Vac | Interrupting Rating at Rated Voltage (50Hz) Vac | Typical DC Cold Resistance (Ω)* | Typical Melting I ² t (amps) | Typical Voltage Drop (mV)‡ |
|--------------|--------------------|---|--|---|----------------------------|
| S506-32-R | 250 | 35 | 21.0 | 0.0051 | 1050 |
| S506-40-R | 250 | 35 | 13.90 | 0.0072 | 920 |
| S506-50-R | 250 | 35 | 9.24 | 0.0095 | 800 |
| S506-63-R | 250 | 35 | 6.96 | 0.021 | 760 |
| S506-80-R | 250 | 35 | 4.42 | 0.038 | 580 |
| S506-100-R | 250 | 35 | 2.74 | 0.045 | 490 |
| S506-125-R | 250 | 35 | 1.97 | 0.063 | 390 |
| S506-160-R | 250 | 35 | 1.27 | 0.093 | 320 |
| S506-200-R | 250 | 35 | 1.00 | 0.114 | 340 |
| S506-250-R | 250 | 35 | 0.640 | 0.265 | 270 |
| S506-315-R | 250 | 35 | 0.450 | 0.621 | 250 |
| S506-400-R | 250 | 35 | 0.308 | 0.872 | 210 |
| S506-500-R | 250 | 35 | 0.183 | 0.827 | 140 |
| S506-630-R | 250 | 35 | 0.186 | 1.33 | 150 |
| S506-800-R | 250 | 35 | 0.128 | 2.78 | 75 |
| S506-1-R | 250 | 35 | 0.0757 | 6.45 | 87.5 |
| S506-1.25-R | 250 | 35 | 0.060 | 10.05 | 86 |
| S506-1.6-R | 250 | 35 | 0.0425 | 21.7 | 82 |
| S506-2-R | 250 | 35 | 0.03325 | 31.6 | 77 |
| S506-2.5-R | 250 | 35 | 0.026 | 59.4 | 75 |
| S506-3.15-R | 250 | 35 | 0.0185 | 96.4 | 68.5 |
| S506-4-R | 250 | 40 | 0.0139 | 71.8 | 67 |
| S506-5-R | 250 | 50 | 0.00985 | 142.5 | 60.5 |
| S506-6.3-R | 250 | 63 | 0.0071 | 237.6 | 51 |
| S506-8-R | 250 | 80 | 0.006 | 255.8 | 55 |
| S506-10-R | 250 | 100 | 0.004 | 450 | 54 |
| S506-12.5-R | 250 | 125 | 0.004 | 1019.5 | 45 |
| S506-15-R | 250 | 125 | 0.004 | 1091.7 | 73 |

* DC Cold Resistance (measured at <10% of rated current)

‡ Typical Voltage Drop (voltage drop was measured at 20°C ambient temperature at rated current)

Nominal Time-Current Characteristics of S506-R

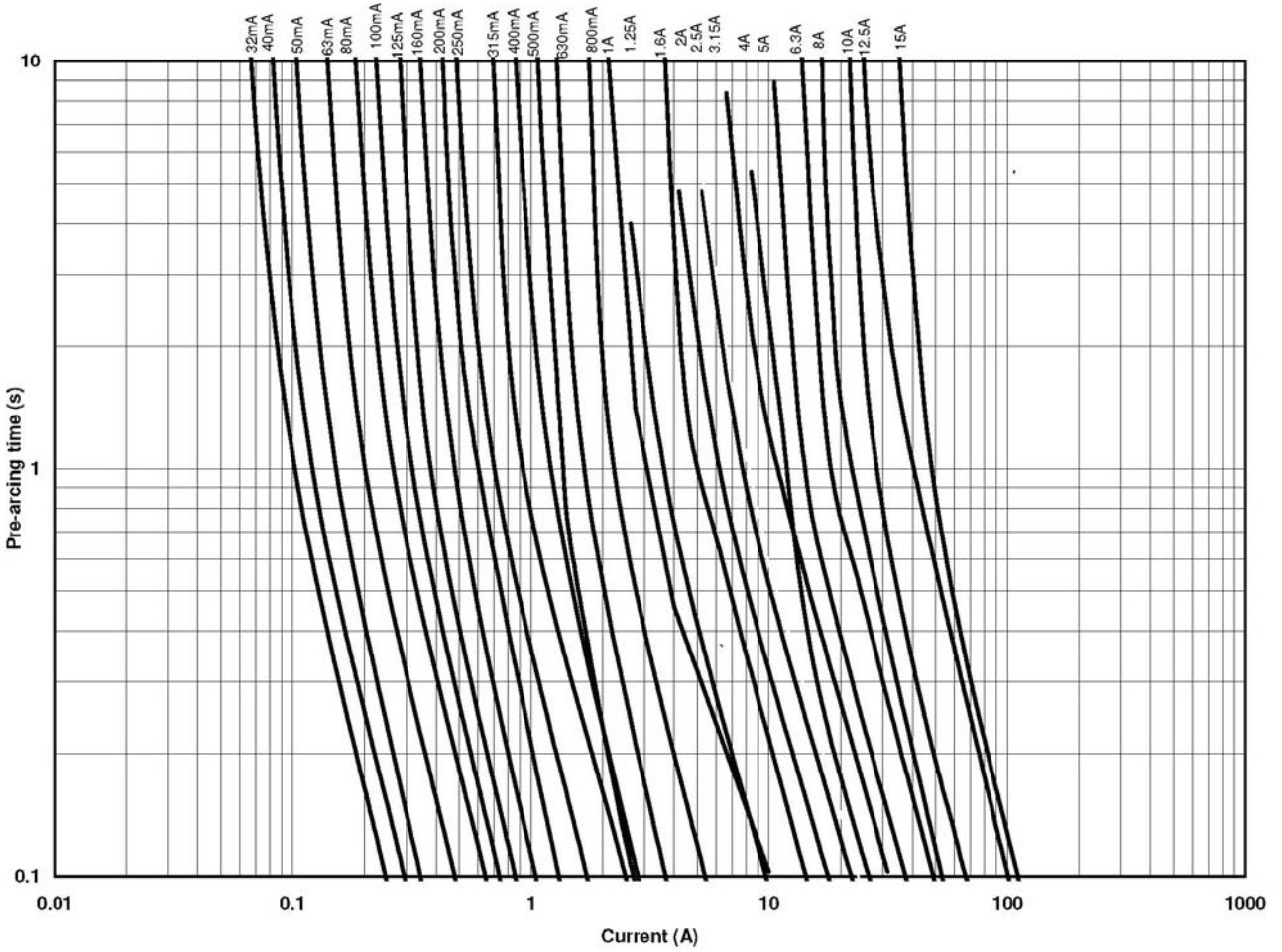

Packaging Code

| Packaging Code Suffix | Description |
|-----------------------|---|
| BK | 100 pieces of fuses packed into a cardboard carton |
| BK1 | 1,000 pieces of fuses packed into a poly bag |
| TR2 | 1,500 pieces of fuses packed into tape on a reel (19.05mm lead wire length) |

Option Code

| Option Code | Description |
|-------------|--|
| V | Axial leads - copper tinned wire with nickel plated brass overcaps |